

MANDATORY

SERVICE BULLETIN

DATE: November 22, 2004 Service Bulletin No. 388C
(Supersedes Service Bulletin No. 388B
and Supplement No. 1 to Service Bulletin No. 388B)

SUBJECT: Procedure to Determine Exhaust Valve and Guide Condition

PART 1 – Use of P/N ST-71 and P/N ST-310 Fixtures

PART 2 – A. Modification to P/N ST-71 and P/N ST-310 Fixtures to Allow
Use of a Dial Indicator
B. Optional Inspection Procedure Using a “Go/No-Go” Gage.

PART 3 – Example of Alternate Tools That Can Be Locally Manufactured

TIME OF COMPLIANCE: Helicopter Engines – 300 hour intervals or earlier if valve sticking suspected.
All Other Engines – 400 hour intervals or earlier if valve sticking suspected
until exhaust valve guides are replaced with guides made of improved
material. (Refer to latest revision of Service Instruction No. 1485.)

To insure positive and trouble free valve train operation, the inspection procedure described in this publication should be accomplished as recommended in the Time of Compliance section of this publication. Failure to comply with the provisions of this publication could result in engine failure due to excessive carbon build up between the valve guide and valve stem resulting in sticking valves or; broken exhaust valves which result from excessive wear (bell-mouthing) of the exhaust valve guide.

This publication describes the approved procedures for checking exhaust valve guide condition.

PART 1 – USE OF P/N ST-71 AND P/N ST-310 FIXTURES TO DETERMINE VALVE GUIDE WEAR OR CARBON BUILD UP

The illustrations used in PART 1 are primarily of a parallel valve cylinder and the P/N ST-71 fixture which uses one adjustable self-locking screw to measure valve stem movement on all parallel valve cylinders. The procedure for inspecting angle valve cylinders with the P/N ST-310 fixture is basically the same. Refer to Figure 2 for fixture installation. Valve guide wear (bell-mouthing) occurs on the inside diameter of the valve guide in a straight line with the center line of the rocker arm. Valve stem movement must be measured by moving the valve stem along this line. The P/N ST-310 fixture incorporates two adjustable self-locking screws located at different angles to accomplish this on two differently designed angle valve cylinder head configurations. Refer to Figure 2.

1. All Engines: Remove the rocker box cover and gasket from the cylinder head.
2. All Engines except "76 Series": Push out the valve rocker shaft and remove the exhaust rocker arm and rotator cap.
3. "76 Series" Engines: Remove valve rocker arm retaining nut, fulcrum, rocker arm, spacer washers and rotator cap.

CAUTION

PHYSICALLY SEPARATE AND IDENTIFY BY CYLINDER EACH VALVE TRAIN PART AS IT IS REMOVED, SO THAT EACH PART MAY BE REASSEMBLED IN EXACTLY THE SAME LOCATION FROM WHICH IT WAS REMOVED.

4. All Engines: Remove push rods, shroud tubes and hydraulic tappet assemblies. Disassemble tappet and clean as described in the applicable overhaul manual.
5. All Engines: Wipe the oil from the top surface of the spring retainer by wiping with a cloth dampened with solvent. This will increase the friction between the valve spring retainer and pressure plate and should eliminate any slippage when the valve stem and spring are moved into position for a measurement.
6. Engines with Sodium Cooled Exhaust Valves: Install the gage adapter over the end of the valve stem and tighten it securely. If the adapter can be rocked on the valve stem by hand, it is not correctly secured. The valve retainer keys do not need to be removed from this type valve stem. Refer to Figure 1.

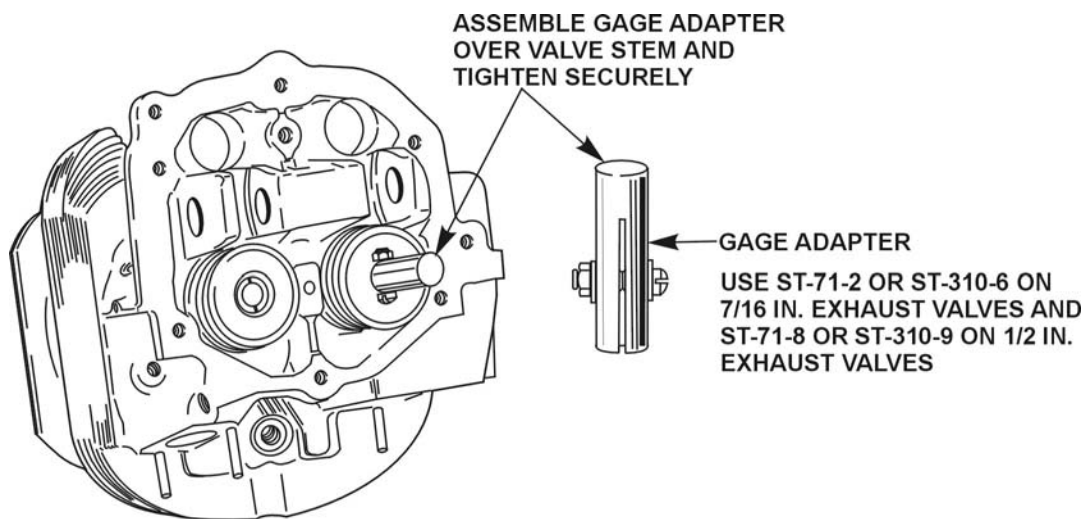
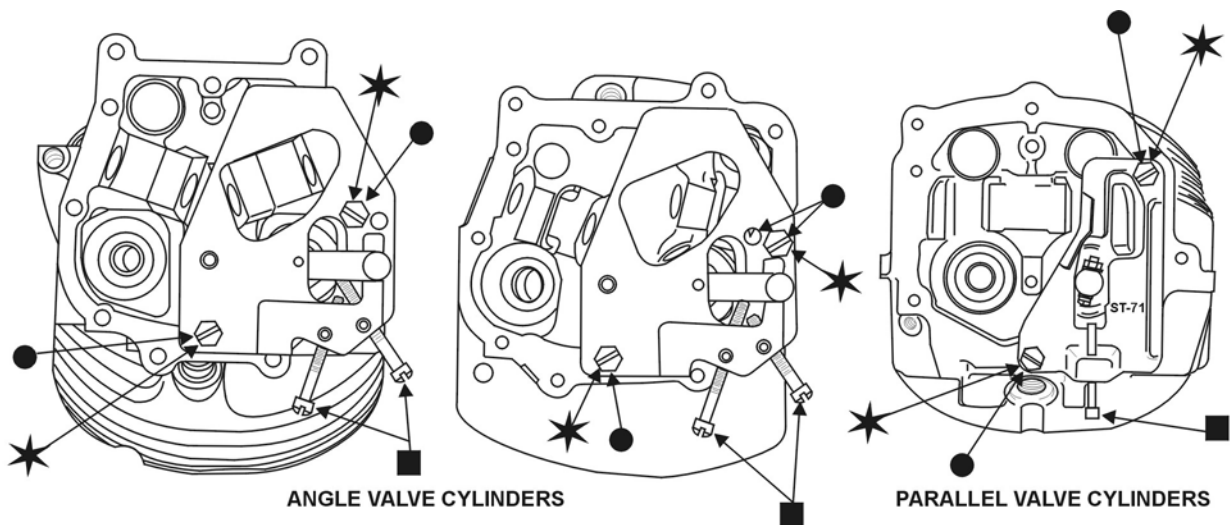

Figure 1. Gage Adapter Assembled on Exhaust Valve Stem

- 6A. Engines with Solid Stem Nonrotator Type Exhaust Valves: The tapered valve retention keys will not allow installation of the split gage adapter and must be removed. Proceed with installation of the P/N ST-71 or P/N ST-310 fixtures until the valve spring is compressed and the tapered keys can be removed. See step 8 for removal of tapered keys.
7. All Engines: Insure the adjustable self-locking set screws on the P/N ST-71 or P/N ST-310 fixtures are backed out (counterclockwise) to avoid interference with the adapter post attached to the valve stem. See Figure 2.



★ TIGHTEN CAP SCREWS EVENLY; ON SOME CYLINDERS CASTING MAY INTERFERE WITH LOWER CAP SCREW, PLACE WASHER UNDER HEAD IF THIS HAPPENS.

■ BEFORE INSTALLING FIXTURE, BACK THIS SCREW OUT TO AVOID INTERFERENCE WITH ADAPTER INSTALLED ON VALVE STEM.

● SOMETIMES INTERFERENCE IS ENCOUNTERED ALIGNING THE FIXTURE BOLT HOLES WITH ROCKER BOX HOLES, THESE 9/32 IN. DIA. HOLES CAN BE ENLARGED TO 3/8 IN. DIA.

Figure 2. Compressor Plate Installed on Cylinder – Angle and Parallel Valve Cylinders

NOTE

Older P/N ST-71 fixtures may require a modification before being used on “76 series” cylinder heads. Refer to Figure 3 for modification dimensions and instructions. Current production P/N ST-71 fixtures include this modification.

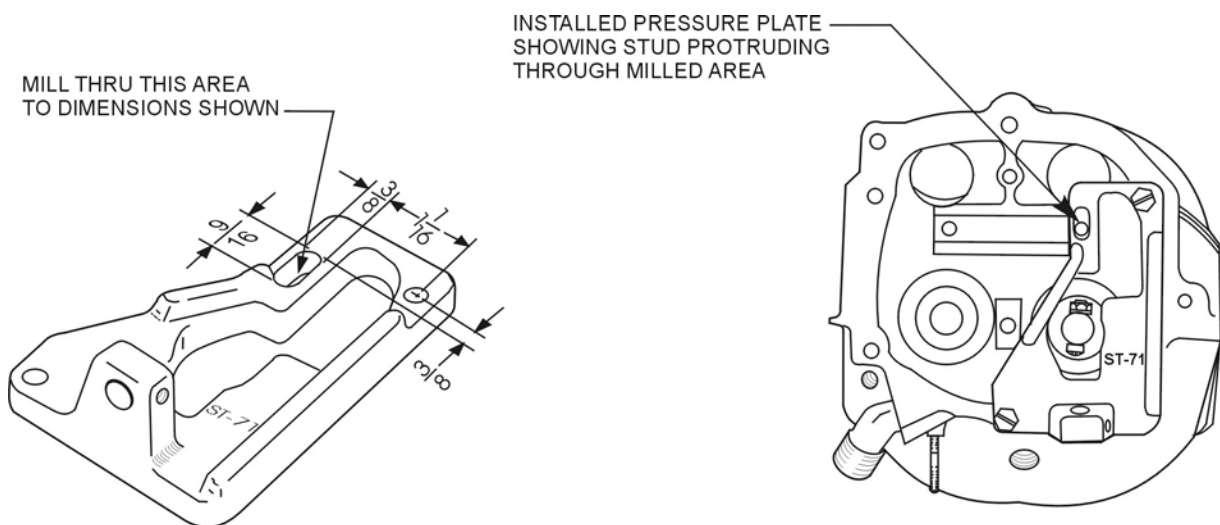

Figure 3. Details for Modifying P/N ST-71 Compressor Plate for use on “76 Series” Engines

8. Engines Equipped with Solid Stem Exhaust Valves: Remove the tapered valve retaining keys by moving the piston of the cylinder being inspected to near its top end of travel. This will eliminate any chance of the valve sliding into the cylinder after the tapered keys are removed. Fabricate a small hooked tool as shown in Figure 4 and insert it between the valve keys engaging the hook of the tool with the underside of the valve tip as shown in Figure 4. Tap on the fixture with a plastic headed hammer while exerting a steady pull on the valve stem, with the hooked tool, until the valve keys release.

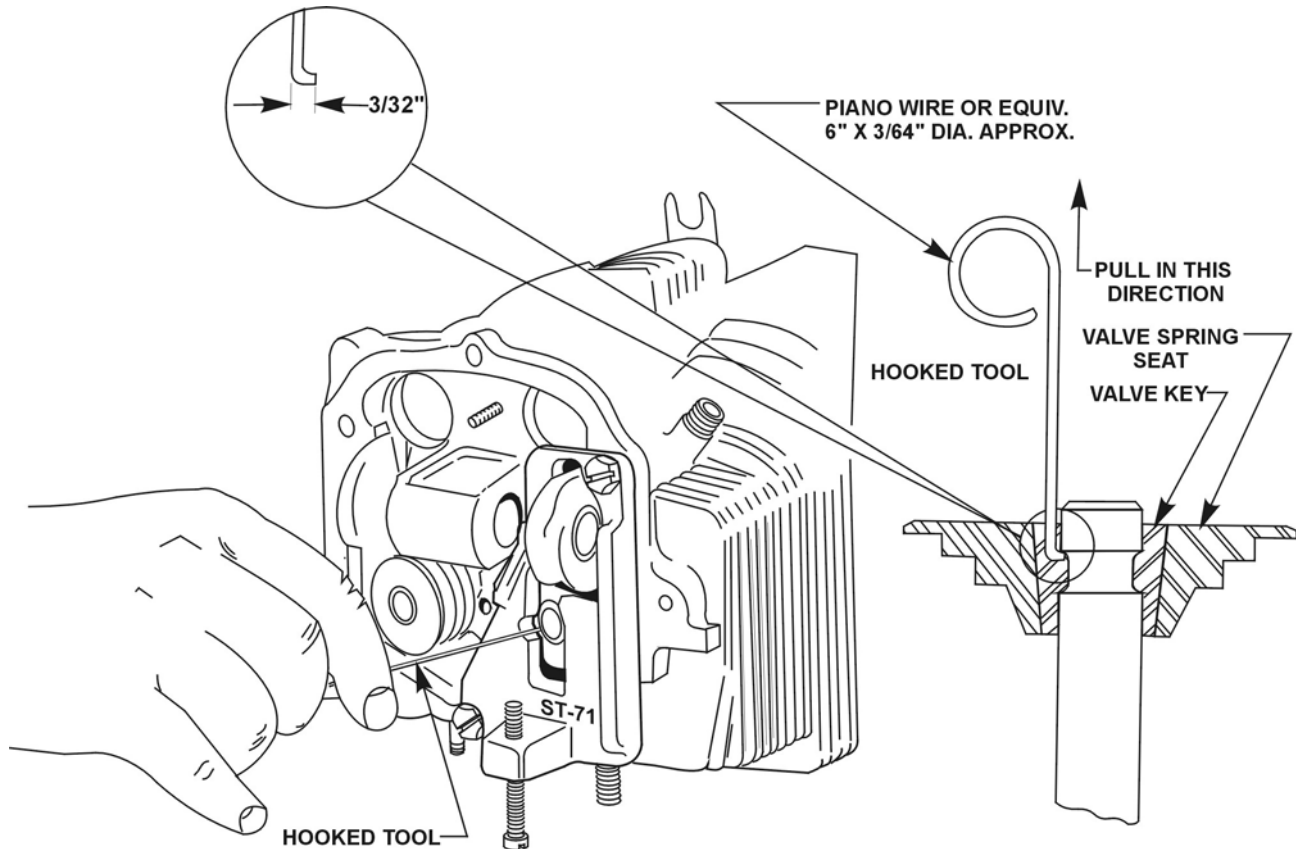

Figure 4. Method of Using Hooked Wire Tool to Pull Valve Into Position for Removal of Tapered Keys

- 8A. If the valve keys do not readily release, remove the pressure plate and using air pressure or 3/8" rope, as described in the latest revision of Service Instruction No. 1425, to hold the valve in the closed position, reinstall the fixture, tapping on it as it is drawn on the cylinder head.
- 8B. Once the valve keys are loosened and removed install the split gage adapter on the end of the valve stem. Release the air pressure or remove the rope and move the piston to near the bottom of its travel.

9. All Engines: Push the assembled valve stem and gage adapter in against the upper spring retainer as far as it will go. This will move the valve off of the seat and eliminate any interference when the valve stem is moved.

NOTE

In the following steps 10 and 11, a screwdriver with a 3/16 inch blade x 4 inch long shank is sufficient to move the valve both ways. Excessive pressure applied to the screwdriver will cause erratic measurements.

10. All Engines: Insert the blade of a screwdriver in the area between the exhaust valve spring and fixture as shown in Figure 5; and using the pressure plate as a fulcrum, press the blade of the screwdriver against the exhaust valve spring, forcing it toward the self-locking set screw as far as it will go. Relax the pressure on the screwdriver. Friction between the fixture and the outer spring retainer should keep the valve stem from returning to its normal position. If the valve stem does have a tendency to move, maintain a slight pressure on the spring with the screwdriver.

CAUTION

DO NOT BUMP ADAPTER POST DURING MEASURING SEQUENCE. ANY MOVEMENT OF GAGE ADAPTER ON VALVE STEM WILL CAUSE FALSE READINGS

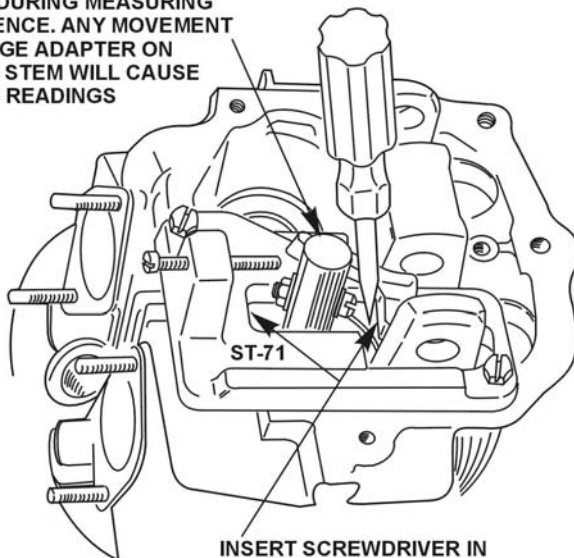

INSERT SCREWDRIVER IN THESE AREAS AND USE THESE TWO SURFACES AS FULCRUMS WHEN PRYING AGAINST VALVE SPRING RETAINER

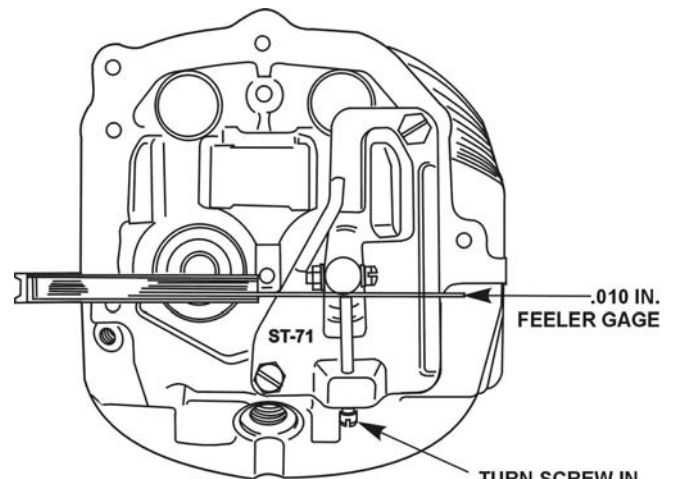

TURN SCREW IN UNTIL IT TOUCHES FEELER GAGE. DO NOT TURN FAR ENOUGH TO MOVE ADAPTER

Figure 5. View Showing Screwdriver in Position to Move Exhaust Valve Stem

Figure 6. Feeler Gage in Position Between Set Screw and Adapter Post

11. All Engines: Using a .010 inch feeler gage between the set screw and gage adapter as shown in Figure 6, turn the set screw toward the gage until a slight drag is obtained on the feeler gage. Do not turn the screw far enough to move the adapter and valve stem.
12. All Engines: Using the screwdriver, push the valve spring as far away from the set screw as it will go, and using a combination of feeler gage blades determine the gap between the tip of the set screw and the gage adapter. Refer to the following Table of acceptable limits.

Valve Guide I.D.	Recommended Allowable Valve Stem Movement	
	Minimum Clearance	Maximum Clearance
.4040/.4050	.010	.030
.4360/.4370	.010	.030
.4370/.4380	.010	.030
.4375/.4385	.010	.030
.4985/.4995	.015	.030
.4995/.5005	.015	.030
.5000/.5010	.015	.035

- 12A. The measurement obtained in step 12 includes the .010 inch used in step 11 as a starting dimension. Determine the actual distance the exhaust valve stem has moved in the following manner.

EXAMPLE

.019 = Total thickness of gage required to measure valve movement.

.010 = Thickness of gage used to establish a starting point.

.009 = Actual amount the valve stem has moved: This indicates insufficient clearance between the valve stem and valve guide which can be corrected by reaming the valve guide I.D. to remove a build up of carbon deposits. (Refer to the latest revision of Service Instruction No. 1425 for valve guide reaming.) Using the same procedure, if the dimension obtained in step 12 had been .038 inch, the actual amount the valve stem moved would be .028 inch indicating that wear on the inside diameter of the valve guide is below the maximum limit and the valve guide is suitable for further service. If valve stem movement is in excess of the maximum limit listed in the table, the valve and guide must be replaced.

13. All Engines: Rotate the piston to near its top end of travel again and remove the gage adapter from the valve stem. Install any valve keys that were removed in step 8 or 8A and insure they are properly seated on the valve stem.
14. All Engines: Remove the fixture from the cylinder by backing out the capscrews alternately to release pressure on valve springs evenly.
15. Engines Equipped with Solid Stem Exhaust Valves: The stem of an exhaust valve, installed in an engine that is operated on highly leaded fuels, can become damaged by erosion or "necking". In addition to the preceding valve stem and guide clearance check, the exhaust valve stems must be examined for this condition. Remove the exhaust manifold and visually inspect the exposed area of the valve stem, between the exhaust valve seat and guide. Any evidence of erosion is reason to replace the exhaust valve and guide.
16. All Engines: Complete the preceding checks on all cylinders, enter the inspection results and any corrective action accomplished in the engine logbook.
17. All Engines Except "76 Series": Using new seals and gaskets, install the hydraulic tappet assemblies, shroud tubes, push rods valve rotator caps (if required), rocker arms and shafts, and check dry tappet clearance. If all parts are returned to their original position, dry tappet clearance will not change. Refer to applicable overhaul manual for dry tappet clearance check.
18. "76 Series" Engines: Using new seals and gaskets, install the hydraulic tappet assembly, shroud tube, push rod, rocker arm fulcrum and spacers, valve rotator cap, and rocker arm. Check dry tappet clearance as described in the applicable overhaul manual. If all parts are returned to their original position and are aligned properly, the dry tappet clearance will not change.

PART 2 – A. MODIFICATION OF P/N ST-71 AND P/N ST-310 FIXTURES TO ALLOW USE OF A DIAL INDICATOR

The procedure described in the preceding PART 1, utilizes a feeler gage to measure the distance the exhaust valve stem has moved. Although this method is satisfactory, it has been found that it is much easier to measure movement of the valve stem if a dial indicator is used instead of the feeler gage. Refer to Figure 7 for modification of a P/N ST-71 fixture and to Figure 8 for modification of a P/N ST-310 fixture.

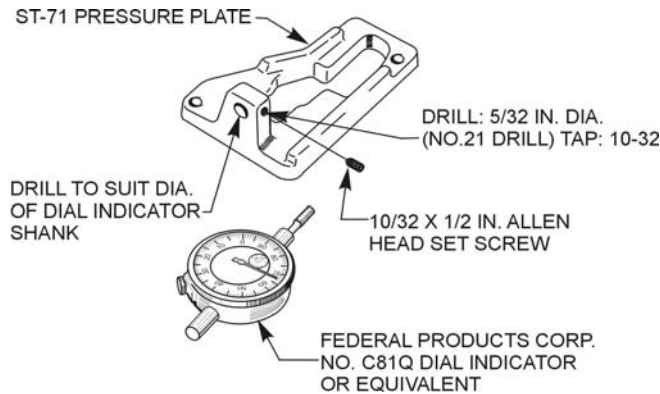

Figure 7. Details for Modifying Tool
P/N ST-71 for Use with a Dial Indicator
(Parallel Valve Cylinders)

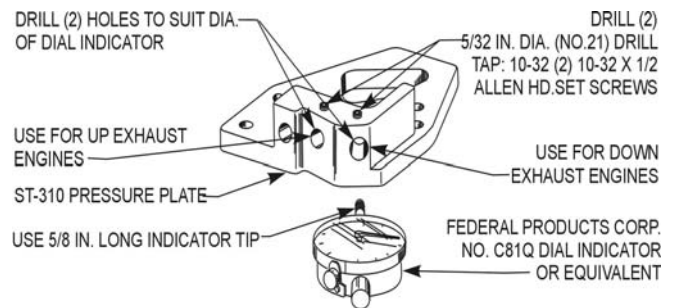
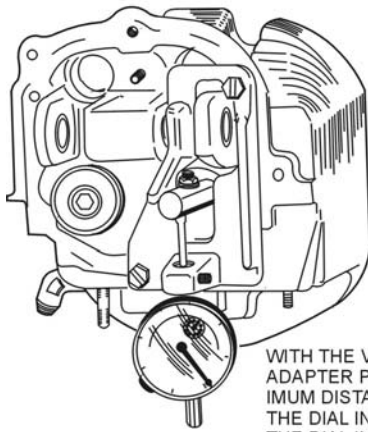

Figure 8. Details for Modifying Tool
P/N ST-310 for Use with a Dial Indicator
(Angle Valve Cylinders)

NOTE

The dial indicator shown in Figure 7, 8, 9 and 10 is Model C81Q manufactured by Federal Products Corp., Providence RI. If a comparable dial indicator is available for use, the adjustment screw holes in the fixtures can be drilled to accommodate the indicator.

1. Install the adapter post and fixture in the same manner as described in PART 1, and push the adapter post and valve stem in against the valve spring retainer as far as it will go.
2. Insert the blade of a screwdriver in the area between the valve spring and fixture and push the valve and adapter post away from the dial indicator as shown in Figure 9.
3. Move the dial indicator toward the adapter post until the indicator is preloaded approximately .010 inch, and lock it in place with the set screw.
4. Adjust the dial of the indicator to read "0" (zero) as shown in Figure 9.
5. Insert the screwdriver between the fixture and valve spring on the opposite side and push the valve spring toward the dial indicator as shown in Figure 10. Relax the screwdriver and record the reading on the dial indicator. The measurement should be within the limits specified in the table with PART 1. If not, perform the required repair procedure as described in PART 1.



WITH THE VALVE STEM AND ADAPTER PUSHED TO ITS MAXIMUM DISTANCE AWAY FROM THE DIAL INDICATOR, PRELOAD THE DIAL INDICATOR TO .010 IN. APPROX. AND LOCK IN PLACE WITH THE SET SCREW. ADJUST DIAL INDICATOR TO 0.

Figure 9. Dial Indicator in Position to Check Valve Guide Clearance

AFTER THE DIAL INDICATOR HAS BEEN PRELOADED USE A SCREWDRIVER TO MOVE VALVE STEM TOWARD DIAL INDICATOR. RELAX PRESSURE ON SCREWDRIVER AND RECORD INDICATOR READING. INDICATOR READING SHOULD BE WITHIN LIMITS SHOWN IN TABLE.

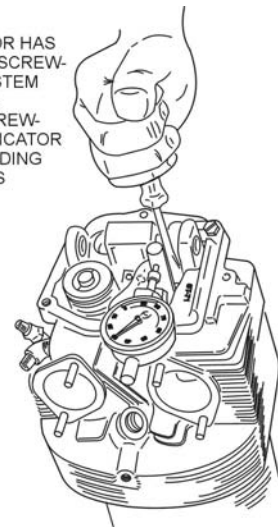

Figure 10. Pushing Valve Stem and Adapter Post Toward Dial Indicator to Establish Valve Guide Condition

PART 2 – B. OPTIONAL INSPECTION PROCEDURE USING A “GO/NO-GO” GAGE.

1. Remove all spark plugs and exhaust manifold. If compressed air is to be used to hold valve, one spark plug should not be removed.
2. Remove rocker box cover and gasket from cylinder.
3. On all engines except the “76 series”, push out rocker shaft to remove exhaust rocker and rotator cap. On “76 series” engines, remove rocker box covers, rocker arm retaining nuts, rocker arm fulcrums, spacer washers, and rocker arms.

CAUTION

PHYSICALLY SEPARATE AND IDENTIFY BY CYLINDER AND VALVE LOCATION, THE VALVE TRAIN COMPONENTS AS THEY ARE DISASSEMBLED, SO THAT EACH PART MAY BE REINSTALLED IN EXACTLY THE SAME LOCATION FROM WHICH IT WAS REMOVED. PAY PARTICULAR ATTENTION TO VALVE STEM KEYS. THESE TEND TO WEAR IN UNIFORM DISTINCTIVE PATTERNS, AND SHOULD BE RETURNED TO THE SAME POSITION AS THEY WERE REMOVED.

4. Position crankshaft just after bottom center on the intake stroke.
5. Insert about 8 feet of 3/8 inch nylon rope through the spark plug hole; then turn the crankshaft until the piston moves the rope snugly against the exhaust valve.
 - a. An alternate technique for holding the valve in position is with air pressure using shop air and a compression check fitting.

CAUTION

THE PISTON IS HELD AT BOTTOM DEAD CENTER BY FIRMLY HOLDING THE PROPELLER TO PREVENT THE ENGINE FROM TURNING WHEN AIR PRESSURE IS APPLIED THROUGH THE DIFFERENTIAL COMPRESSION DEVICE TO THE COMBUSTION CHAMBER. USE GLOVES OR RAGS TO PROTECT THE HANDS WHILE HOLDING THE PROPELLER BLADE. ALSO, BEFORE ATTACHING THE COMPRESSION TESTER, CHECK THE AIR SUPPLY REGULATOR TO MAKE SURE THE AIR PRESSURE TO THE CYLINDER IS NOT EXCESSIVE. AIR PRESSURE IN THE CYLINDER CAN CAUSE THE PROPELLER TO TURN. KEEP CLEAR OF THE PATH OF THE BLADES.

6. Compress the exhaust valve spring and remove valve keys. (The rope or air pressure inserted in the combustion chamber in the preceding step provides a base to support the valve in the event the keys tend to stick.)
7. Remove the nylon rope or bleed off the air pressure and insert light through the upper spark plug hole. Then start pushing the valve from its guide. Before the valve stem is free from the guide, secure it from falling into the cylinder with mechanical pickup fingers, working through the spark plug holes and/or exhaust ports as shown in Figure 11.



Figure 11. View Through Exhaust Port Showing Mechanical Fingers Holding Valve Stem

8. Move the valve (secured by the mechanical fingers) completely out of the guide and position it away from the guide to avoid interference when using GO/NO-GO gage made in accordance with following table.

Nominal Exhaust Valve Guide ID	GO Gage	NO-GO Gage
.4045	.4040	*
.4375	.4370	*
.4380	.4375	*
.4990	.4985	*
.5000	.4995	.001 per 100 hrs
.5005	.5000	*

* - This gage to be sized in accordance with Table of Limits, SSP-1776, for hours on engine.

9. With the appropriate gage (GO/NO-GO), check the valve guide for either wear or carbon build up.
 - a. The NO-GO gage must not enter. If it does, the valve guide has had too much wear and must be replaced in accordance with the overhaul manual procedure.
 - b. The GO gage side must enter totally inside the valve guide; if such is not the case or if there is a friction point, ream the guide in accordance with latest revision of Service Instruction No. 1425.
10. Using a magnetic pencil and flexible mechanical fingers, position tip of valve in guide and very carefully work the valve back into its guide. Extreme caution should be exercised during this operation, making sure the valve is placed within the guide and not cocked, as damage could be done to the guide or valve.

CAUTION

NEVER USE THE PISTON TO PUSH THE VALVE THROUGH THE GUIDE.

11. Install valve springs and valve spring seats in same position as removed. Compress valve spring and install keys in their respective position. In some cases it has been found that when the valve spring is compressed, the valve slides down the guide, making it impossible to install the keys. If this condition exists, reinsert the nylon rope (steps 4. and 5.) to hold valve firmly on its seat while installing valve keys.
12. Remove hydraulic lifter and clean free of all oil, inspect for any malfunction. Clean ID of cam follower. Reinstall hydraulic lifter.
13. Install push rod, then rotating cap, rocker arm and shaft.
14. Check dry tappet clearance in accordance with the Service Table of Limits in the appropriate Lycoming Overhaul Manual.
15. Install rocker box cover and new gasket.

CAUTION

DURING REASSEMBLY, VALVE TRAIN COMPONENTS MUST BE REPLACED IN THEIR ORIGINAL LOCATION. ON "76 SERIES" ENGINES, GIVE SPECIAL ATTENTION DURING REASSEMBLY TO ALIGNMENT OF ROCKER ARMS, SPACERS AND ROCKER ARM FULCRUMS WITH THE ROCKER ARM RETAINING STUD. ALL PARTS MUST BE IN PROPER ALIGNMENT TO ASSURE CORRECT DRY TAPPET CLEARANCE. MISALIGNMENT COULD RESULT IN ENGINE DAMAGE.

16. Make sure all flashlights, ropes, etc. have been removed from within the cylinder before proceeding to the next cylinder.
17. Install spark plugs. (Install exhaust manifold after all exhaust valve guides are cleaned.)
18. Make appropriate logbook entry.

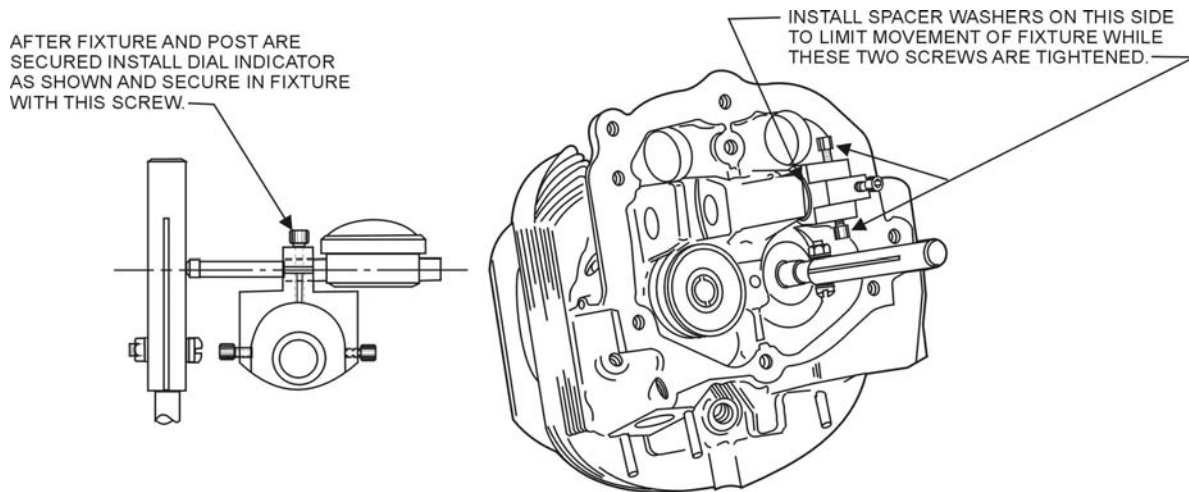

Figure 13. Tool Mounted on Rocker Arm Shaft – Parallel Valve Cylinder

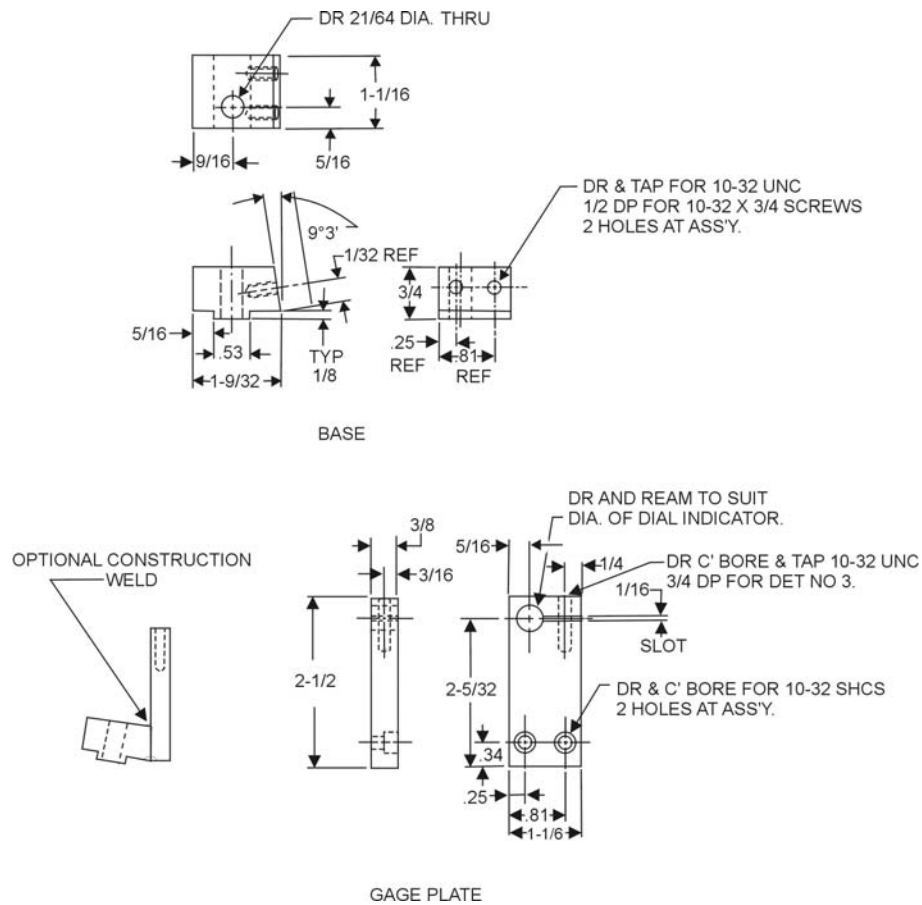

Figure 14. Detail of Tool for "76 Series" Cylinders

The procedure for measuring valve stem movement is the same as described in PART 2, except that a slight fingertip pressure must remain against the valve stem as the dial indicator is preloaded, and again when the valve stem and adapter post are moved toward the dial indicator until the dial indicator reading is recorded.

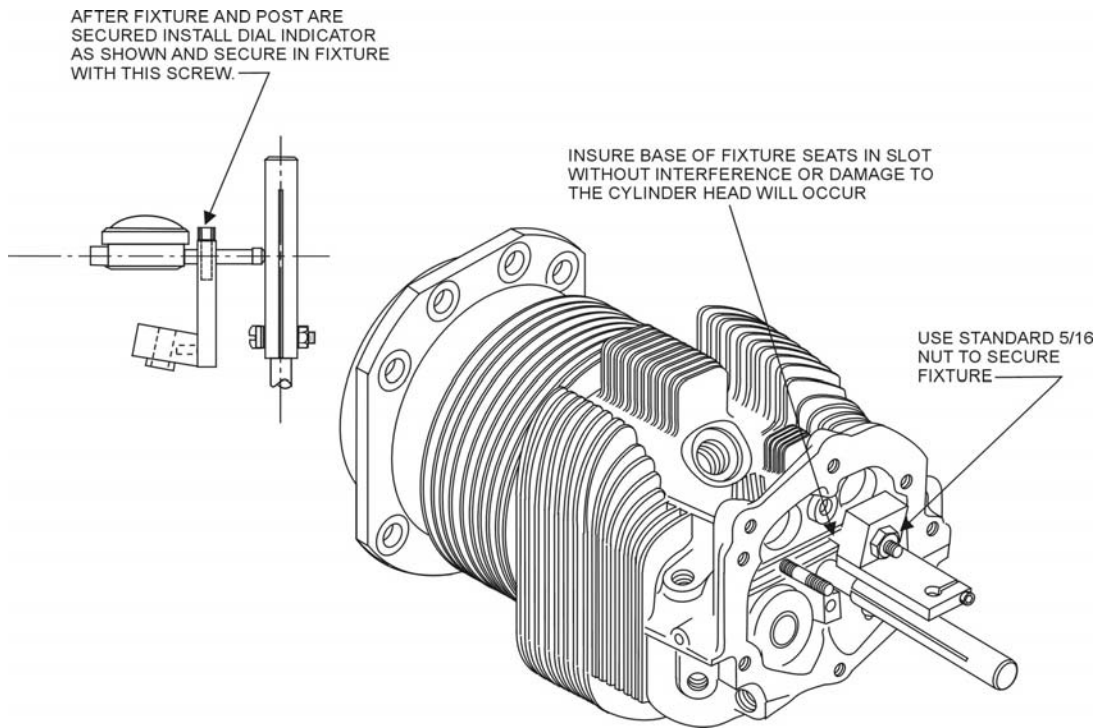
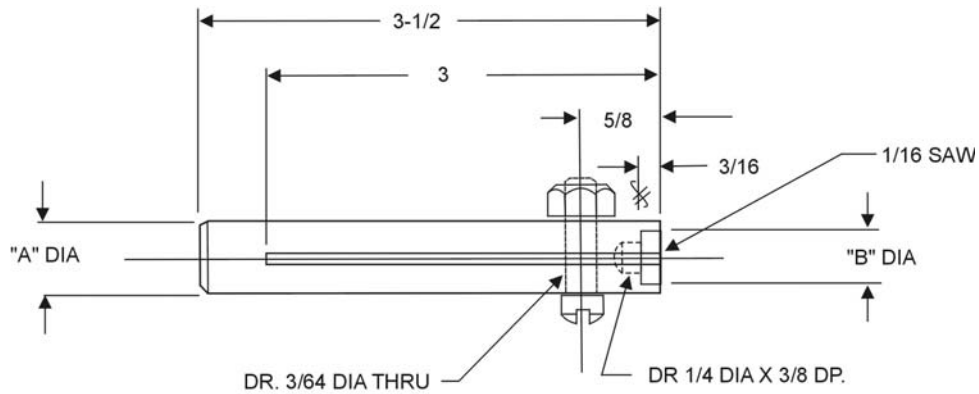

Figure 15. Tool Mounted on "76 Series" Cylinder Head

NOTE

The tools described in this section locate the tip of the measuring instrument 2-1/2 inches from the top of the valve guide. This dimension should be maintained on all locally manufactured tools.



7/16 ASS'Y A = 9/16, B = .402-405 RM.

1/2 ASS'Y A = 5/8, B = .498-496 RM.

DIAMETERS "A" AND "B" MUST BE CONCENTRIC

Figure 16. Adapter Post – Required with Both Tools

NOTE: Revision "C" combines Service Bulletin No. 388B and Supplement No. 1 to Service Bulletin No. 388B and adds dimensions for fabrication of a tool to measure wobble.